

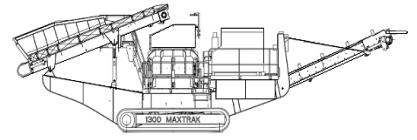

TEREX | PEGSON

1300 MAXTRAK SPECIFICATION



CONE CRUSHER

- Crusher type:** 1300 Automax Crusher.
- Liners:** Manganese steel alloy mantle and concave.
- Standard concave:** Medium Coarse.
- Lubrication:** Pumped system having a chassis mounted lube tank with airblast cooler.
- Adjustment:** Hydraulic setting adjustment, automatic overload release and hydraulic unblocking.
- Control:** System 2 hydraulic controls as standard.
- Concave options:** Autosand (AS).
- Drive:** Wedge belt drive from engine via HFO clutch.

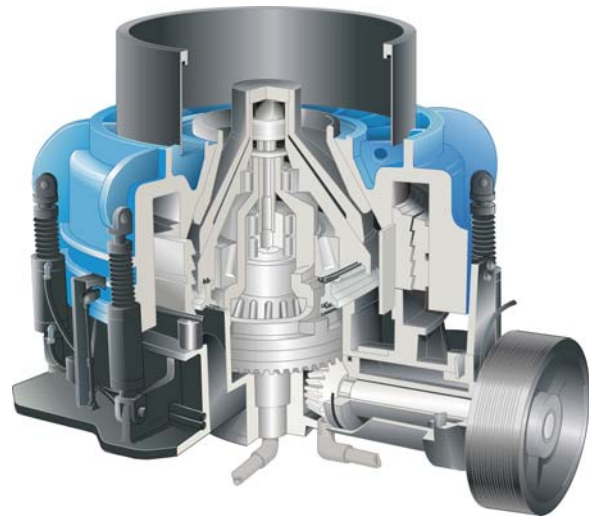

CRUSHER OPTIONS

CRUSHER	MAXIMUM FEED SIZE	MAXIMUM RECOMMENDED CSS
1300 Automax	220mm	44mm
1300 Autosand	63mm	30mm

1300 MAXTRAK SPECIFICATION

HOPPER

Hopper type:	Fixed feed hopper.
Hopper length:	3.5m.
Hopper width:	2.79m.
Hopper capacity:	Up to 7.0m ³ gross depending on method of feed.
Hopper body:	10mm thick Hardox wear resistant steel plate, fitted with crash bar to minimise impact on the feed conveyor.



ON PLANT FEED CONVEYOR

Conveyor type:	Shallow troughed belt variable speed conveyor.
Design:	Conveyor is designed to lower for transport and raise hydraulically for operation and crusher maintenance.
Belt type:	EP630/4 with 6mm top and 2mm bottom heavy-duty rubber covers, and vulcanised joint.
Belt adjustment:	Belt tensioning is by use of screw adjustment at the tail shaft.
Belt width:	1.3m.
Belt length:	5.4m.
Feed height:	3.17m.
Drive:	Hydraulic motor drive via flange mounted gearbox.
Impact rollers:	Provided immediately below the feed hopper.
Metal detector:	Suitable for detecting steel and manganese, complete with audible warning device and connected to stop the feed conveyor.

Barge boards:

Extend from the feed conveyor to the conveyor head.

Lubrication:

Oil for head drum gearbox. Grease nipples for lubrication of shaft bearings. Crusher feed ring fitted with level probe designed to give optimum flow of material in to the crusher when plant is overfed.

Level probe:



ON PLANT PRODUCT CONVEYOR

Conveyor type:	Troughed belt fixed speed conveyor with hydraulic drive to head drum.
Belt type:	EP500/3 with 5mm top and 1.5mm bottom heavy-duty rubber covers, and vulcanised joint.
Belt width:	1m.
Discharge height:	3.46m.
Drive:	Direct drive hydraulic motor
Impact rollers:	Provided immediately below the crusher outlet.

Belt covers:

Canvas type removable dust covers are fitted over the exposed section of the conveyor.

Belt adjustment:

Belt tensioning is by use of screw adjustment at the head drum.

Lubrication:

Grease nipples for lubrication of shaft bearings.

Speed Sensor:

Designed to stop plant feed when discharge conveyor stops.

1300 MAXTRAK SPECIFICATION

POWERPACK

Powerpack type: Caterpillar C-12
Performance: 438HP (327kW) at 1800 rpm at sea level.
Engine: Six cylinders, four stroke, direct Injection.
Fuel tank capacity: 509 Litres.



CLUTCH

Clutch type: High efficiency, self-adjusting HFO clutch with electro-hydraulic operation.

DUST SUPPRESSION SPRAYS

Sprays bars with atomiser nozzles are mounted over the crusher mouth and the product conveyor feed and discharge points piped to an inlet manifold for clients pressured water supply.

Type: Clean water multi atomising nozzles.
Inlet: Single Point.
Pressure required: 2.8 bar (42 psi).
Water supply: 23 litres per minute.
Frost Protection: Via system drain valves.
Pump: **Optional extra.**



TRACK DRIVE

Type: Heavy-duty tracks fitted as standard.
Pitch: 190mm.
Longitudinal centres: 3800 mm.
Track width: 500 mm.
Climbing grade: 29° maximum.
High speed: 0.9 km/hr.
Slow speed: 0.322 km/hr.
Drive: Two integral hydraulic motors.
Track tensioning: Hydraulic adjuster, grease tension.



GUARDS

Wire mesh or sheet metal guards are provided for all drives, flywheels, pulleys & couplings.

The guards provided are designed and manufactured to CE & ANSI standards.



1300 MAXTRAK SPECIFICATION

PLATFORMS

Platforms are provided for inspection and maintenance, allowing access to each side of the crusher, rear of engine and one side of the feed conveyor head section. They are made from steel flooring with steel toe boards, double row handrails and access ladders.



CHASSIS

Heavy duty fabricated I section of welded construction.



CRUSHER CONTROLS

The hydraulic systems control panel is mounted on the side of the main chassis.

This enables crusher-setting changes to be made and to calibrate and monitor manganese wear.

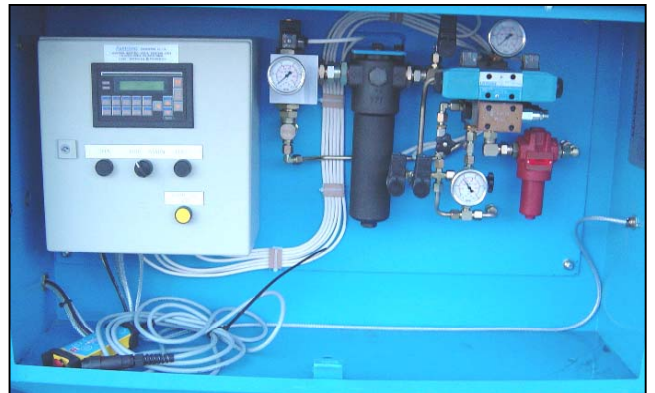

PLANT CONTROLS

A Control panel is also fitted onto the plant to operate the following items: -

- Crusher (Start/Stop).
- Oil pump (Start/Stop).
- Discharge conveyor (Start/Stop).
- Feed conveyor (Start/Stop/Speed).
- Crusher level controls.

A control lever is also mounted onto the plant to operate the raising and lowering of the feed conveyor assembly for transport and maintenance.



1300 MAXTRAK SPECIFICATION

UMBILICAL CONTROL

An umbilical control unit is also supplied with the plant. This is used to control the tracking function and is also fitted with a stop button for the plant.



OPTIONAL EXTRAS

(For prices refer to your dealer)

- Autosand concave.
- Feed hopper extensions plates designed to give 3.7m over the rear of hopper (to be removed for road transport).
- Single idler belt weigher with integrator and speed sensing wheel fitted to the main product conveyor.
- Electric refuelling pump kit.
- Radio remote control.
- Additional level sensor over feed hopper necessary for applications where plant may be underfed.

RECOMMENDED OPTIONAL EXTRAS

- Engine fire extinguisher system.
- Hydraulic driven water pump assembly to provide a pressurised water supply to the dust suppression sprays.

REMOTE CONTROL (OPTIONAL EXTRA)

The remote radio control is provided with controls for the tracking function and a stop button for the plant. **This facility is only available in certain countries where type approval has been obtained.** For a full list of countries, please consult TP or your dealer.



1300 MAXTRAK SPECIFICATION

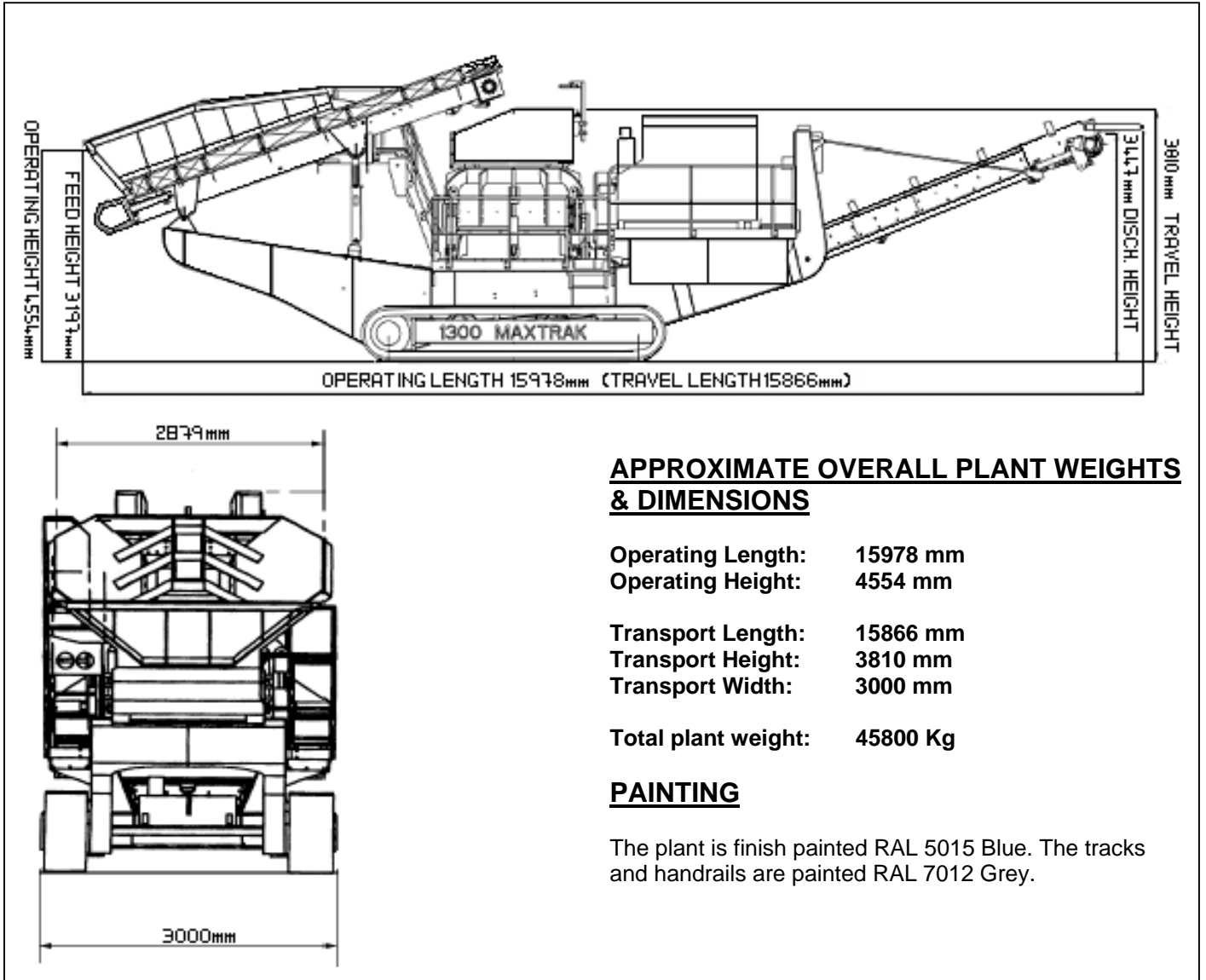

APPROXIMATE OVERALL PLANT WEIGHTS & DIMENSIONS

Operating Length: 15978 mm
Operating Height: 4554 mm

Transport Length: 15866 mm
Transport Height: 3810 mm
Transport Width: 3000 mm

Total plant weight: 45800 Kg

PAINTING

The plant is finish painted RAL 5015 Blue. The tracks and handrails are painted RAL 7012 Grey.

General

TEREX | Pegson equipment complies with CE requirements.

Please consult TEREX | Pegson if you have any other specific requirements in respect of guarding, noise or vibration levels, dust emissions, or any other factors relevant to health and safety measures or environmental protection needs. On receipt of specific requests, we will endeavour to ascertain the need for additional equipment and, if appropriate, quote extra to contract prices. Every endeavour will be made to supply equipment as specified, but we reserve the right, where necessary, to amend the specifications without prior notice as we operate a policy of continual product development. It is the importers responsibility to check that all equipment supplied complies with local legislation.